



# Compounding Pharmacy - HVAC Controls, Design Requirements and Sequences of Operation

Matt Costick

Midwest Hospital Engineering Conference 2023

# Agenda



- Standards
- Requirements
- Control Sequences Available to Meet Requirements
- Insights From Prior Projects

# Standards & Enforcement



- United States Pharmacopeia (USP)
- Facilities Guidelines Institute (FGI)
- ASHRAE 170

# Standards - USP



Non-Sterile Preparations		Sterile Preparations	
Non-Hazardous Drugs	Hazardous Drugs	Non-Hazardous Drugs	Hazardous Drugs
USP 795	USP 795 USP 800	USP 797	USP 797 USP800

# Standards - USP



Non-Sterile Preparations		Sterile Preparations	
Non-Hazardous Drugs	Hazardous Drugs	Non-Hazardous Drugs	Hazardous Drugs
USP 795	USP 795 USP 800	USP 797	USP 797 USP800

- All updated Nov 2022, Enforcement Starts Nov 2023
- Great Link to Summary of Changes by ASHP
- <https://www.ashp.org/-/media/assets/pharmacy-practice/resource-centers/compounding/docs/USP-797-Key-Changes.pdf>

# Standards - USP



Non-Sterile Preparations		Sterile Preparations	
Non-Hazardous Drugs	Hazardous Drugs	Non-Hazardous Drugs	Hazardous Drugs
USP 795	USP 795 USP 800	USP 797	USP 797 USP800

- All updated Nov 2022, Enforcement Starts Nov 2023
- Great Link to Summary of Changes by ASHP
- <https://www.ashp.org/-/media/assets/pharmacy-practice/resource-centers/compounding/docs/USP-797-Key-Changes.pdf>

# Requirements



**USP: Guidebook to Pharmaceutical Compounding: Sterile Preparations. Rockville, MD: United States Pharmacopeia Convention, 2008. Print.**

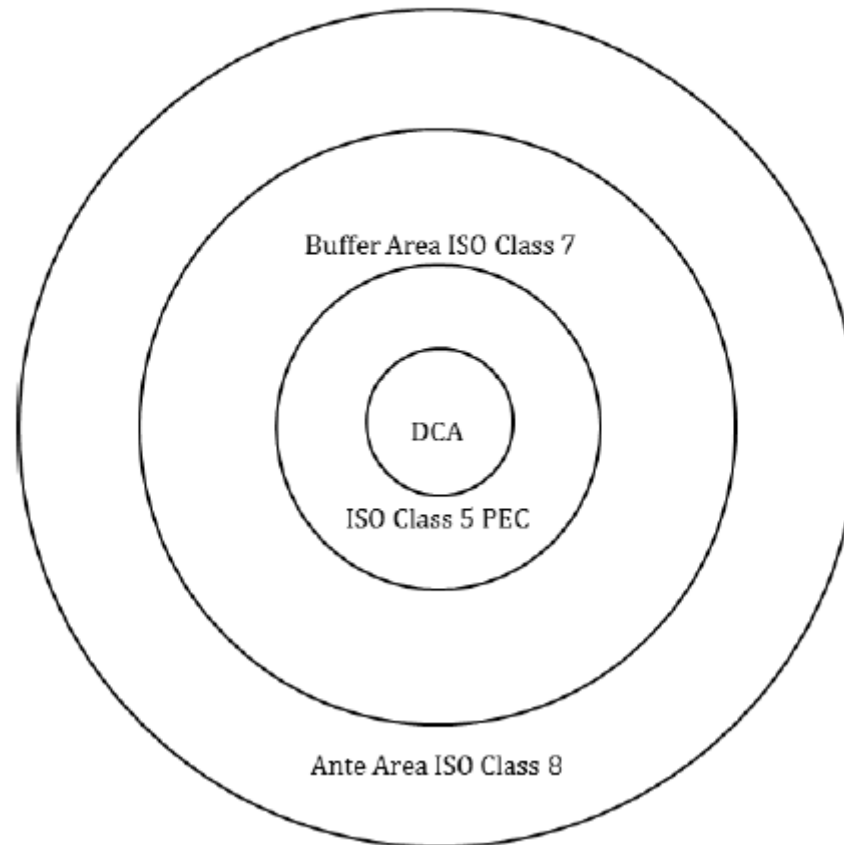

# Requirements

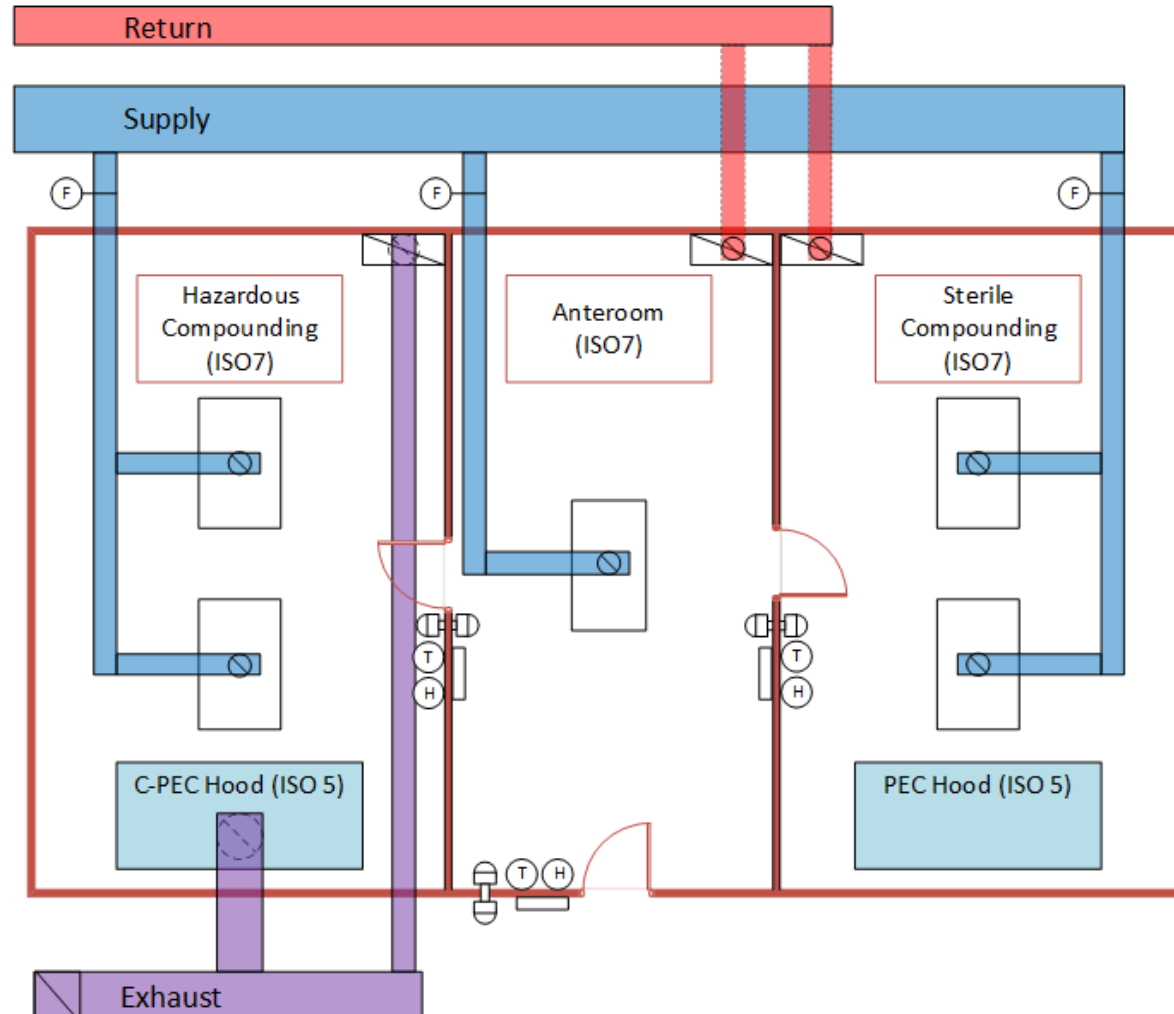



# Requirements



	<b>Anteroom</b>	<b>Non-Hazardous Compounding</b>	<b>Hazardous Compounding</b>	<b>Hazardous Storage</b>
Differential Pressure	+ .020 to .050" WC	+ .020 to .050" WC	- .010 to .030	- .010 to .030
Air Changes / Hour	30 ACH	30 ACH	30 ACH	12 ACH
Temperature	Below 68 F (62-65)	Below 68 F (62-65)	Below 68 F (62-65)	
Relative Humidity	Below 60% RH	Below 60% RH	Below 60% RH	
Exhaust / Return			Externally Ventilated	Externally Ventilated

# Requirements



	Anteroom	PEC	Non-Hazardous Compounding	Hazardous Compounding	Hazardous Storage
ISO 5		X			
ISO 7	X		X	X	
ISO 8*	X				

# Requirements



- Third party testing, Environmental Monitoring Program
  - All flows, temperatures, and pressures
  - All ISO levels – Particle counts to pass ISO requirements
  - Testing for viable particles in air and on surfaces
  
- All done every 6 months

# Control Sequences Available to Meet Requirements

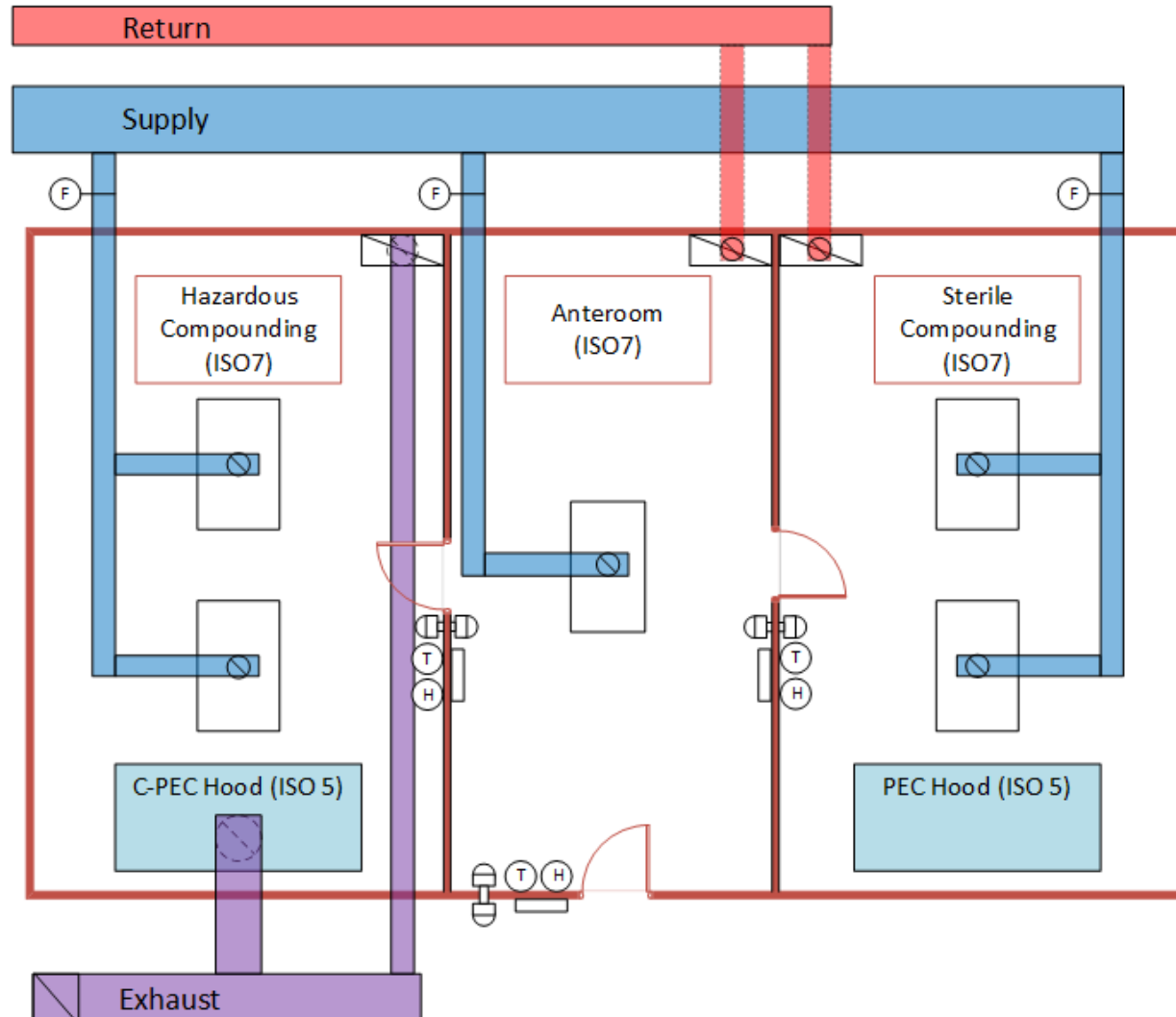

# Control Sequences Available to Meet Requirements



- Constant Volume
- Variable Volume

# Control Sequences Available to Meet Requirements



- Constant Volume

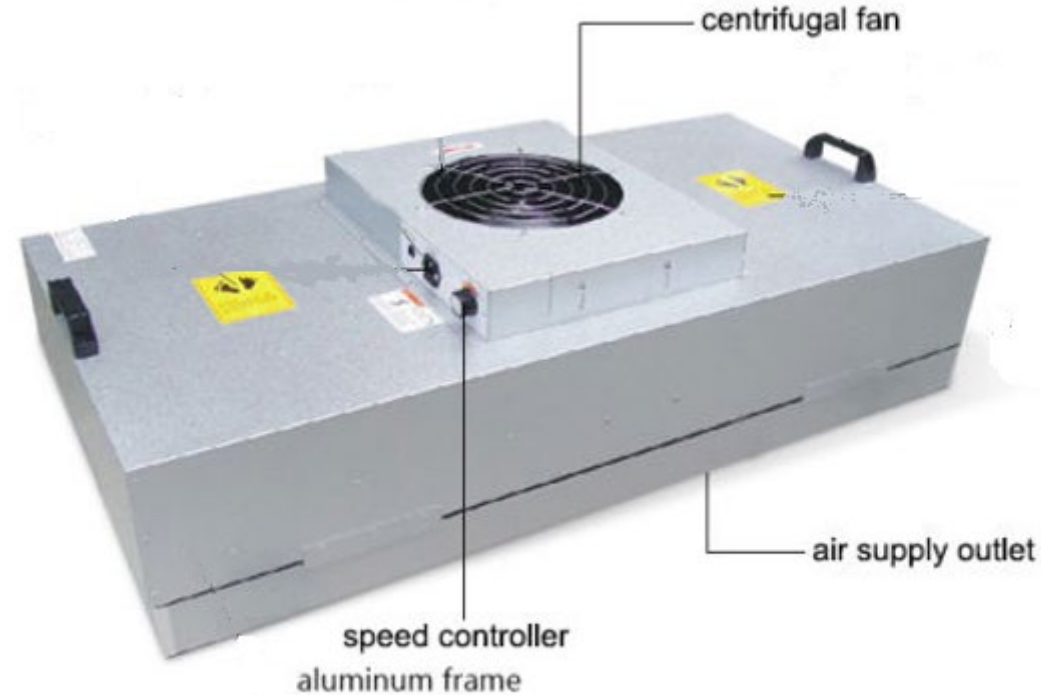

# Control Sequences Available to Meet Requirements

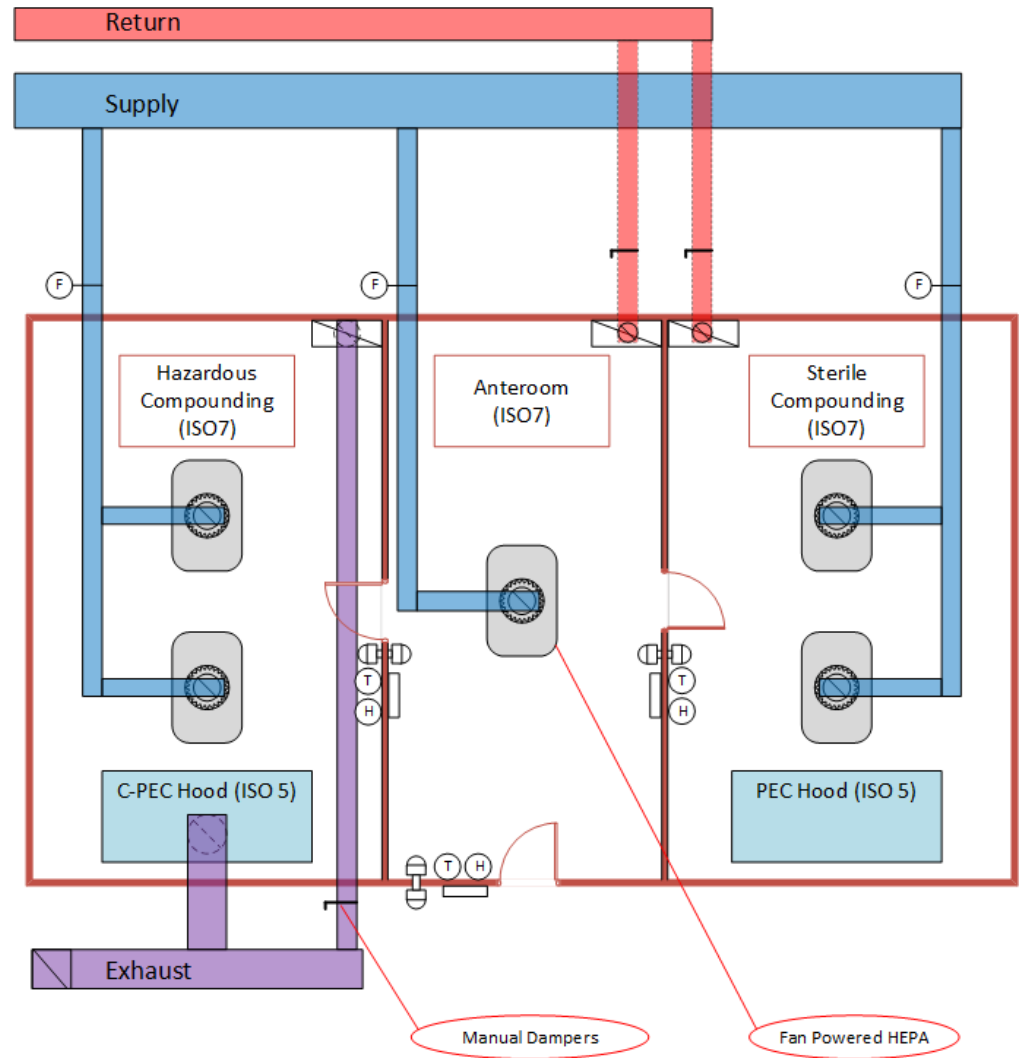

# Control Sequences Available to Meet Requirements



- Variable Volume

HEPA / Diffuser

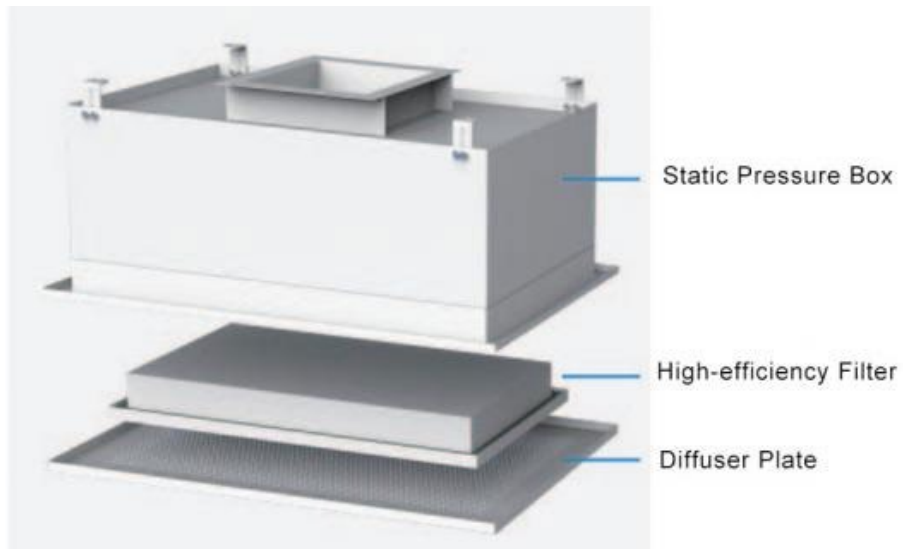

Damper





# Control Sequences Available to Meet Requirements

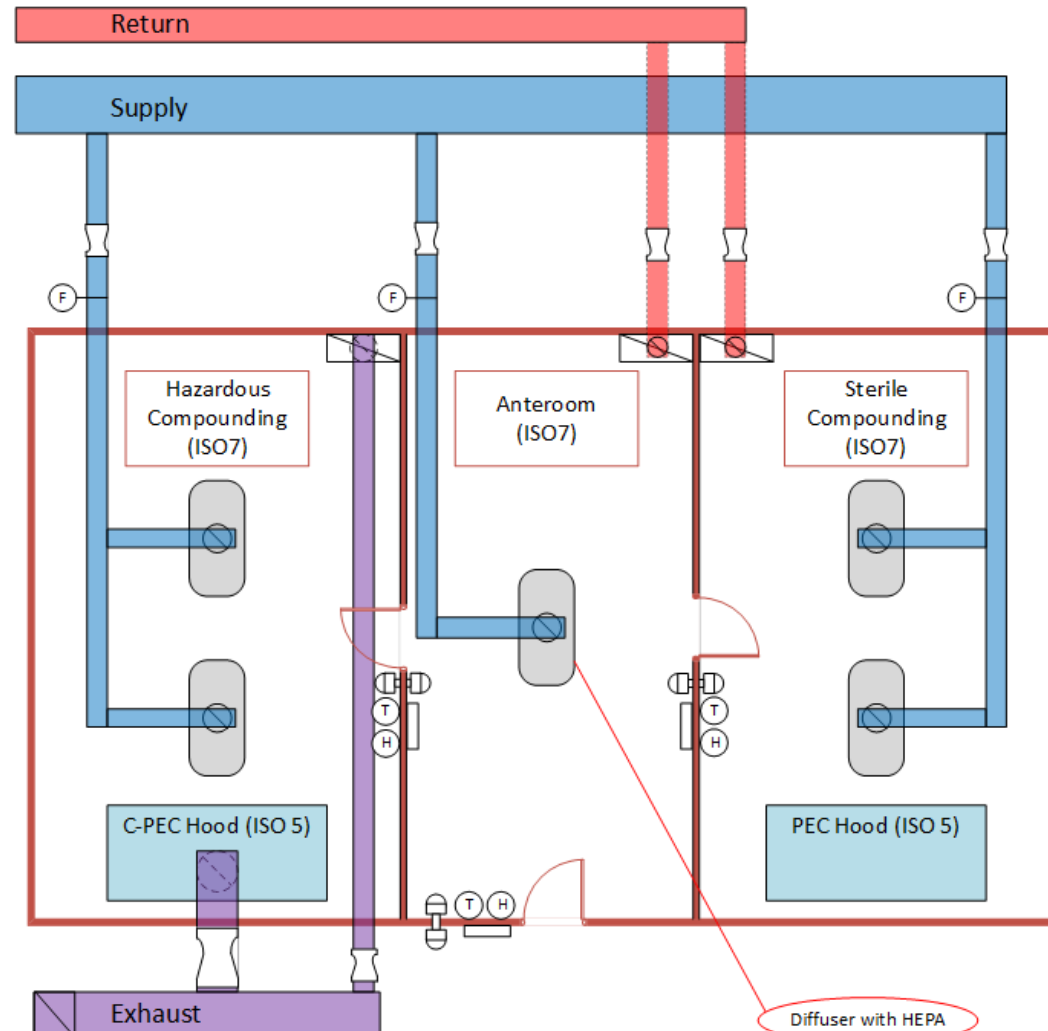

# Insights From Prior Projects



	Anteroom	Non-Hazardous Compounding	Hazardous Compounding	Hazardous Storage
Differential Pressure	+ .020 to .050" WC	+ .020 to .050" WC	- .010 to .030	- .010 to .030
Air Changes / Hour	30 ACH	30 ACH	30 ACH	12 ACH
Temperature	Below 68 F (62-65)	Below 68 F (62-65)	Below 68 F (62-65)	
Relative Humidity	Below 60% RH	Below 60% RH	Below 60% RH	
Exhaust / Return			Externally Ventilated	Externally Ventilated

	Anteroom	PEC	Non-Hazardous Compounding	Hazardous Compounding	Hazardous Storage
ISO 5		X			
ISO 7	X		X	X	
ISO 8*	X				

# Insights From Prior Projects

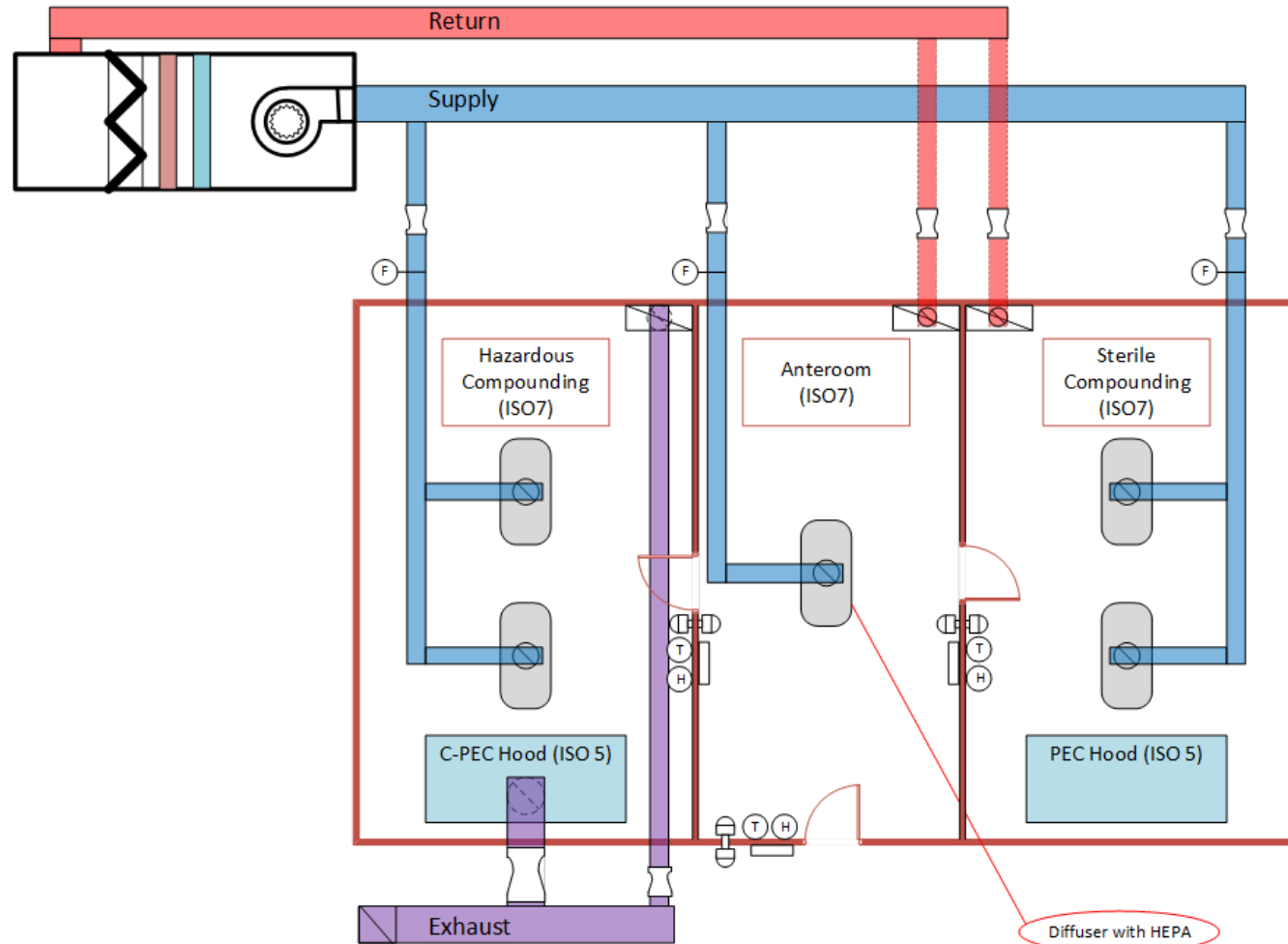

# Insights From Prior Projects

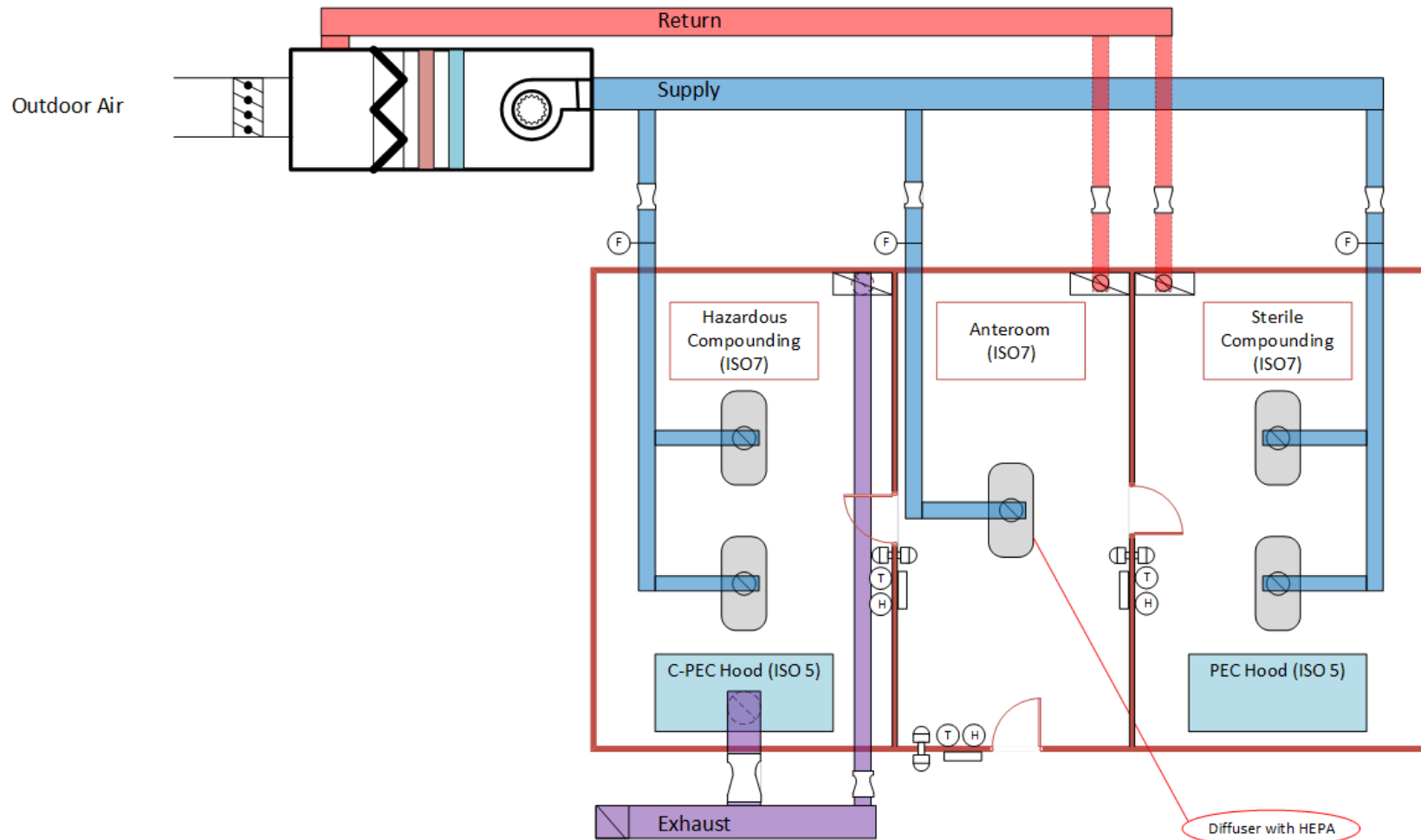

# Agenda



- Standards
- Requirements
- Control Sequences Available to Meet Requirements
- Insights From Prior Projects

# Questions?